

# PR 1710-series

## Digital weighing transmitter

### Intrinsically safe weighing transmitter

global weighing technologies

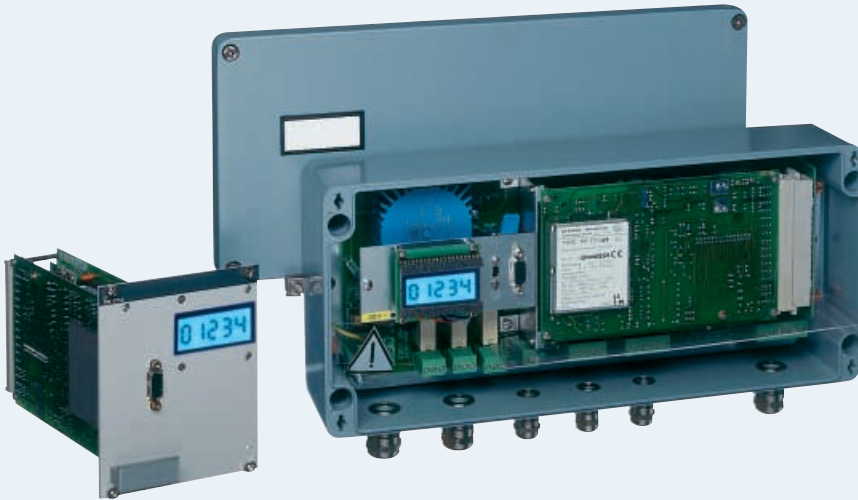

- Accuracy of 3000 d class III (EN 45501)
- Serial communication interface (RS 232 or TTY or RS 485/422)
- Option: convenient 5-digit LCD display
- Configurable analogue output 0/4-20 mA
- 3 configurable inputs, 3 configurable outputs
- Userfriendly, menu-prompted configuration without separate SW
- Calibration without weights (Smart Calibration)
- CENELEC approval; galvanic isolation of the measuring signal

#### PRODUCT PROFILE

You are looking for integral process automation and you want to integrate scales in your system. These transmitters easily meet the highest weighing requirements. Whether your application requires analogue or digital signals via bus systems, these transmitters cover nearly all needs for modern automation processes. For local process control you just choose the PR 1710 with LCD display.

For hazardous area applications we provide an intrinsically safe version, which is approved according to CENELEC [EEx ib] II B/C.

To enable easy linkage to automation systems, you have the choice between different serial communication lines such as RS 232 or TTY or RS 485/422. Furthermore, several common bus protocols are already implemented.

#### DESCRIPTION

The PR 1710 series transmitters are available in single Euroformat for 19" racks or in an IP 65 field version. Load cells are connectable by 6-wire technique.

To reduce the possibility of EMI, all inputs and outputs are galvanically isolated. Mechanical vibrations of the weighing structure can be effectively suppressed by means of an analogue filter. Additionally, a configurable software filter smoothes the distortion of the measuring signal which occurs under sudden load variations.

The digital transmitter has a userfriendly, menu-prompted setup. A separate serial line (RS 232) is accessible via standard SUB-D connector and allows calibration and configuration by a PC or terminal (VT 100-compatible).

These instruments allow calibration without weights for fast and easy commissioning.

All calibration and configuration parameters are stored in an EEPROM to avoid the loss of data in the case of a power breakdown.

#### BENEFITS

- Improved process performance
- Consistent results
- Higher up-time
- Lower maintenance costs
- Flexibility

```

Digital Transmitter PR1710-PR1711 rel 01.07rev 21.01.1998
Operating level

< > 1710kg

actual I/O | 1 2 3
dig. input | Off Off Off
dig. output | Off On Off
limits | On Off On
ana. output | 9.47mA= 34.2%

Operating options

I tare in G show gross M modify markers
O tare out N show net L set limits/fixtare
Z set zero T show tare C enter configuration
? start test

```

Main screen showing the prompts of the operating level menu

## TECHNICAL DATA

### Type of construction

PR 1710/xx: Single Euroformat  
 Height: 3 HE (128.4 mm)  
 Width without display: 10 TE (50.5 mm)  
 Width with display: 21 TE (106.3 mm)

### Connector type

3\*16 pole connector  
 (IEC I30-14, DIN 41612)  
 Standard matching plug: e. g. with solder eyelet from Schroff (69001-712)

### PR 171 I/xx: Field housing

Protection class IP 65  
 Display: 5 digits 7-segment LCD  
 Height: 10.2 mm  
 Viewing area: 45.7 x 17.7 mm

### Connection

Via 6 cable glands

### Configuration/Calibration

Via PC or terminal, VT 100 compatible

### Supply voltage

PR 1710/xx:  
 18 to 33 V<sub>DC</sub>, +/- 15 V<sub>DC</sub> (+/- 6.6 %)  
 24 V<sub>AC</sub> (+10/-15 %)  
 Power consumption: 7 W, 9 VA  
 PR 171 I/xx:  
 115/230 V<sub>AC</sub> (+10/-15 %)  
 Power consumption: 10.5 VA  
 Optional on request:  
 18 to 33 V<sub>DC</sub>, 24 V<sub>AC</sub> (+10/-15 %)

### Service interface

Via front at PR 1710/xx or internal at PR 171 I/xx  
 9-pole D-SUB connector RS 232, 9.6 kB for PC or terminal;  
 Functions: calibration, configuration, monitoring

### Communsiation interface

RS 232, RS 422/485 or current loop selectable with order  
 Maximum baudrate: 19.2 kB (4.8 kB for CL)

### Protocols

EW-Bus, remote display, Modbus/Jbus, DUST 3964R, Siemens 3964R-RK5 12, Profibus DP/FMS via a separate unit

### Control inputs

3, optodecoupled, 0-5 V (Status 0)  
 10-31 V (Status I); passive

### Control outputs

PR 1710/xx:  
 3, optodecoupled, max. 31 V<sub>DC</sub>, 25 mA

### PR 1711/xx:

3, via relays  
 Contact duty 250 V<sub>AC</sub>  
 5A  
 Derating for DC 250 V<sub>DC</sub> / 0.3 A  
 100 V<sub>DC</sub> / 0.5 A  
 30 V<sub>DC</sub> / 1.5 A

### Analogue output

0/4 to 20 mA, max. burden 500 Ω;  
 configurable for various weights (e.g. G, N, T, D)  
 Update rate: proportional to measuring time  
 Resolution: 12 bit

### Accuracy class

3000 d class III (EN 45501, O1ML R76)

### Load cell connection

All strain gauge load cells;  
 6 or 4 wire connection possible

### Load cell supply

12 V or 7 V<sub>DC</sub>, selectable

### Load impedance

Min. 87.5 Ω;  
 e.g. 6 load cells with 600 Ω each or 4 load cells with 350 Ω each

### Input signal

Total range: 0 to 36 mV  
 Minimum span:  
 0.3 mV/V for 3000 d (OIML) or 0.04 mV/V for 3000 counts internal

### Dead load range:

36 mV – (max. span) Span and deadload adjustment via software during calibration

### Measuring principle

A/D conversion: integrating converter, ratiometric to LC supply  
 Conversion rate: 50 ms  
 Measuring time: 50 ms; 100 ms or multiples

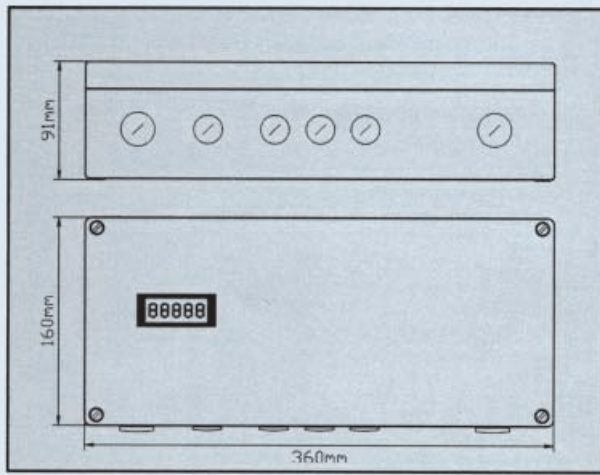

PR 1711 dimensions in mm

PIN	RS485/422	RS232	C.L.
d 2	SIGN.GND	RTS	N.C.
d 4	TX B	TX	TX IN
d 6	TX A	RX	TX OUT
d 8	RX B	CTS	RX IN
d 10	RX A	SIGN.GND	RX OUT

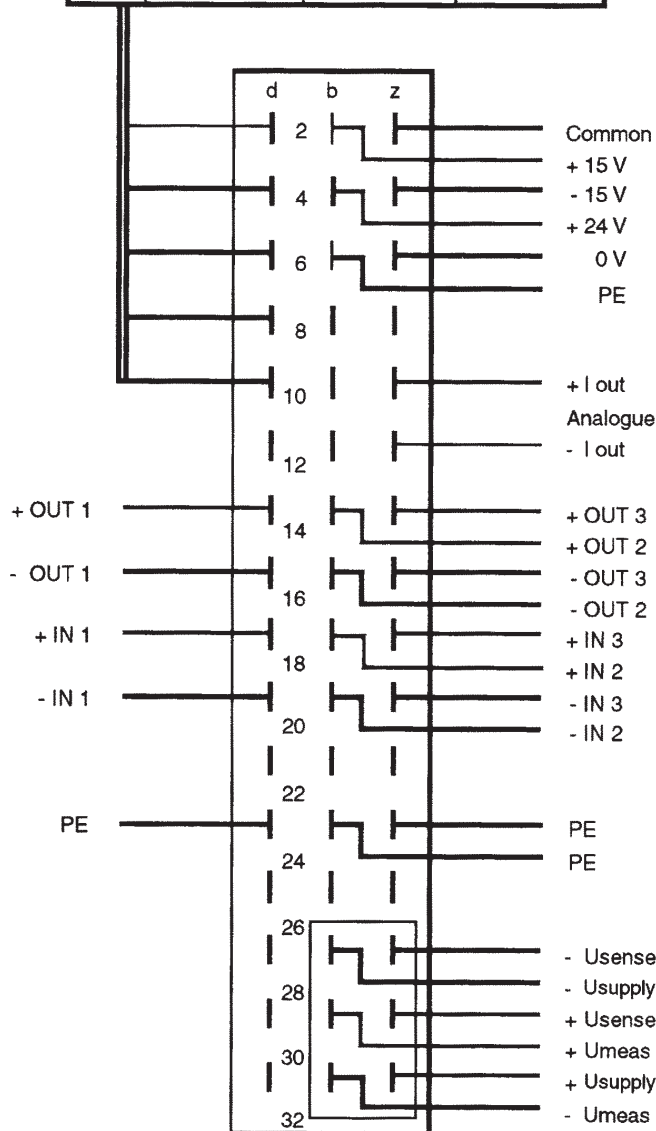

PR 1710 pin connection

**Sensitivity (internal)**

0.16  $\mu\text{V}/\text{count}$   
 >75000 counts for 12 mV  
 >210000 counts for 36 mV

**Analogue filter**

Active Butterworth low-pass filter  
 40 dB/decade,  
 2 Hz cut-off frequency

**Linearity error**

<0.007 %

**Temperature effects**

Tk0 <1  $\mu\text{V}/10\text{ K}$   
 Tkspan <0.006 %/10 K

**Net weight/shipping weight**

PR 1710: 0.7 kg/1.2 kg  
 PR 1711/xx: 4.8 kg/6.1 kg

**Approvals:**

CENELEC [Ex ib] II B/C

**ENVIRONMENTAL CONDITIONS**

**Vibration safety**

According to IEC 68-2-6, test Fc

**Static discharge**

According to IEC 10004-2

**Electromagnetic fields**

According to IEC 10004-3  
 26 MHz to 1 GHz

**Interference on mains and inputs/outputs**

According to IEC 10004-4

**Radio noise suppression**

According to EN 5501 1

**Electrical safety**

IEC 1010-1

**Temperature range**

Operation: -10 °C to +55 °C  
 Storage: -40 °C to +70 °C

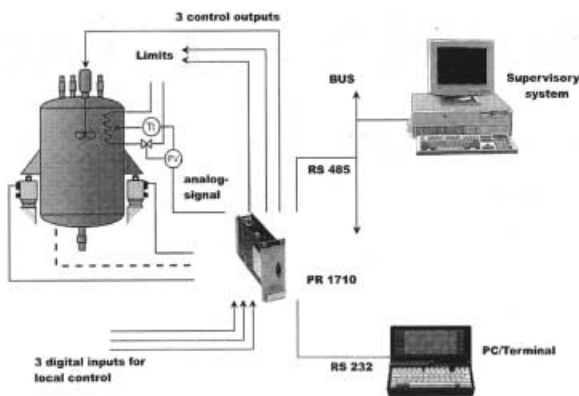

Typical application using a PR 1710/xx

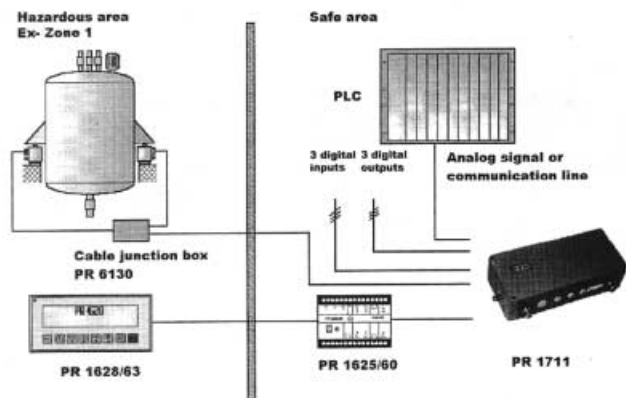

Typical application in a hazardous area using PR 1711 with Ex-remote display PR 1628

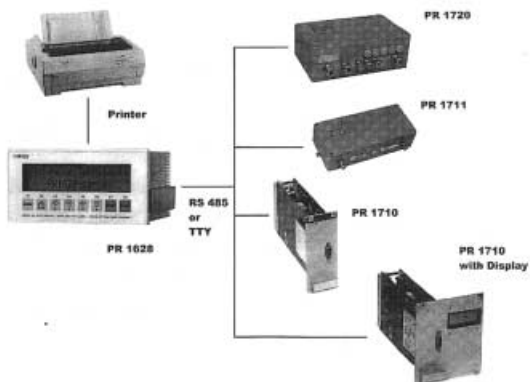

Control of several transmitters via one PR 1628 remote display (up to 8 instruments)

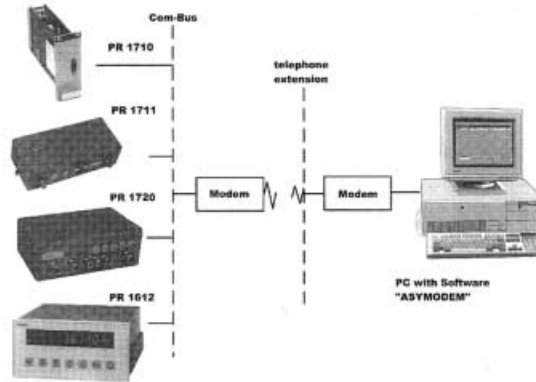

Remote control via ASYMODEM software (up to 16 instruments)

## ORDER NUMBERS

### Single Euroformat:

PR 1710 without display

PR 1710/01 (with current loop)

PR 1710/02 (with RS 232)

PR 1710/04 (with RS 422/485)



PR 1710 with display

PR 1710/11 (with current loop)

PR 1710/12 (with RS 232)

PR 1710/14 (with RS 422/485)



PR 1710 (Ex) intrinsically safe without display

PR 1710/61 (with current loop)

PR 1710/62 (with RS 232)

PR 1710/64 (with RS 422/485)



PR 1710 (Ex) intrinsically safe with display

PR 1710/71 (with current loop)

PR 1710/72 (with RS 232)

PR 1710/74 (with RS 422/485)



Fieldversion:

PR 1711 (Ex) intrinsically safe with display

PR 1711/61 (with Current loop)

PR 1711/62 (with RS 232)

PR 1711/64 (with RS 422/485)

